

XE245i LR

LONG REACH EXCAVATOR

Bucket Capacity : 0.5 cu.m > 0.45 cu.m

Engine Make : Cummins

Engine Power : 141.4 hp

Operating Weight : 22800 kg



ENGINE

| | |
|-------------|------------------------------------|
| Model | Cummins 6BT5.9 |
| Type | 6 Cylinder, 4 Stroke, Turbocharged |
| Rated Power | 141.4 hp @ 2000 rpm |
| Batteries | 12 V x 2 |
| Max Torque | 564 Nm @ 1600 rpm |

HYDRAULIC SYSTEM

| | |
|-------------|----------------|
| Main Pumps | 2 Piston Pumps |
| Max Flow | 2X224 lpm |
| Pilot Pump | 3.9 MPa |
| Swing Speed | 13 rpm |

RELIEF VALVE SETTINGS

| | |
|----------------------------|----------|
| Main Safety Valve Pressure | 34.3MPa |
| Swing System Pressure | 28 MPa |
| Travel System Pressure | 34.3 MPa |
| Pilot System Pressure | 3.9 MPa |

UNDERCARRIAGE

| | |
|-------------------------|------------|
| Max Travel Speed | 5.5 km/h |
| Max traction Force | 184 kN |
| Gradeability | 35 degrees |
| No of Upper Roller/Side | 2 |
| No of Lower Roller/Side | 9 |
| No of track Shoes/Side | 49 |
| Shoe width | 800 mm |

SERVICE REFILL CAPACITIES

| | |
|-------------------------|-------|
| Fuel Tank | 360 L |
| Engine Coolant | 23 L |
| Engine Oil | 16 L |
| Travel device(Per side) | 5 L |
| Swing Device | 5 L |
| Hydraulic Tank | 220 L |
| Hydraulic System | 300 L |

WORKING RANGE

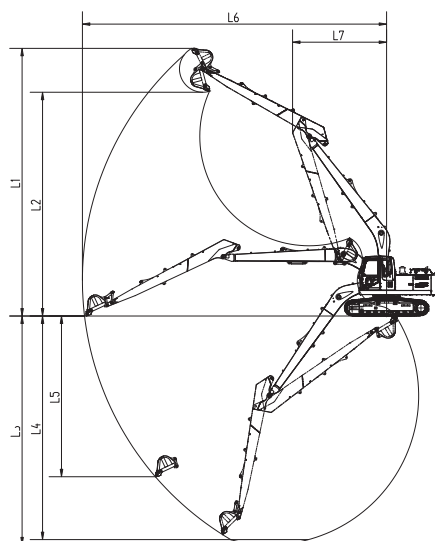

WORKING RANGE

Working Range (unit: mm)

| | | |
|----|------------------------------------|-------|
| L1 | Max. digging height | 13500 |
| L2 | Max. dumping height | 11150 |
| L3 | Max. digging depth | 11610 |
| L4 | Max. depth cut (8 ft) level bottom | |
| L5 | Max. vertical wall digging depth | 8800 |
| L6 | Max. vertical wall | 15430 |
| L6 | Min. swing radius | 4730 |

DIMENSION

DIMENSION (unit : mm)

BOOM 8.14 m
ARM 6.34 m

| | | |
|---|-----------------------------------|-------|
| A | Overall Length | 12130 |
| B | Overall Width | 3190 |
| C | Overall Height | 3034 |
| D | Width of Platform | 2830 |
| E | Length of Crawler/Track | 4449 |
| F | Overall Width of Crawler | 3190 |
| G | Track Shoe Width | 800 |
| H | Tumbler Distance | 3370 |
| I | Track Gauge | 2390 |
| J | Ground Clearance of Counterweight | 1050 |
| K | Min. Ground Clearance | 477 |
| L | Min. Tail Swing Radius | 2890 |
| M | Height of Track | 927 |

DIMENSION

